

Figures from SC-R2 zone depicting various standards. These are identical or close to the comparable standards in the "preliminary /HA-JWR2" zone.

Figure 9.3065(2)(c)1

Alley Open Space

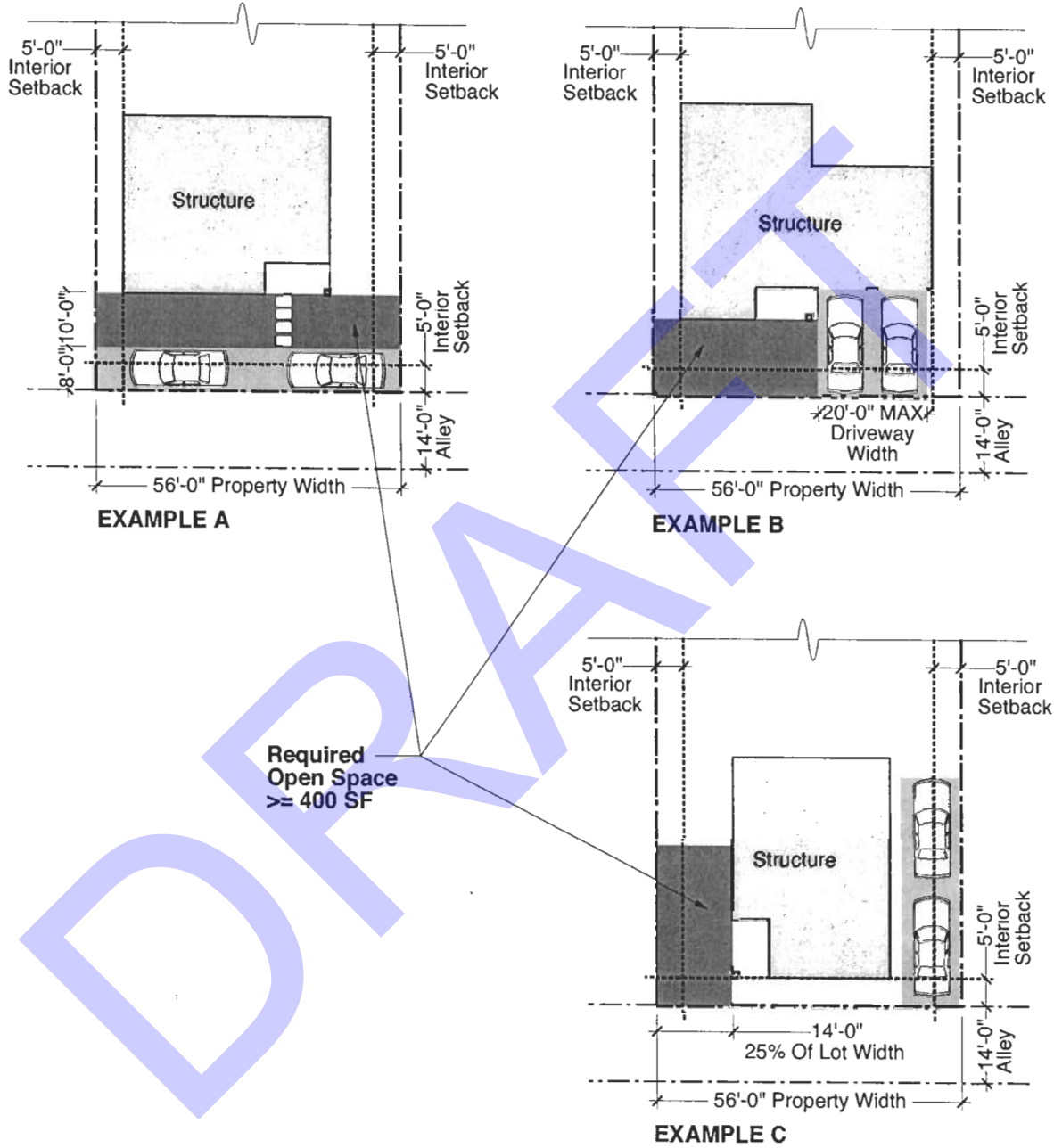
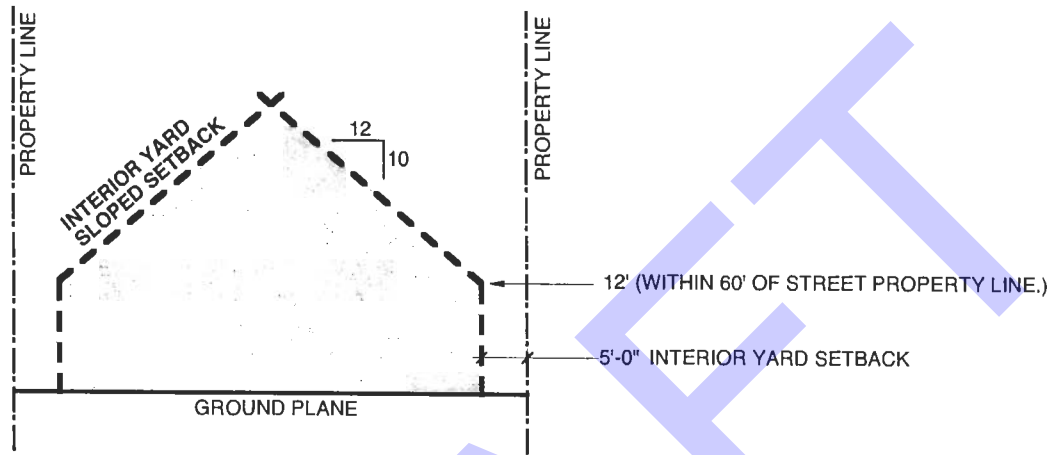
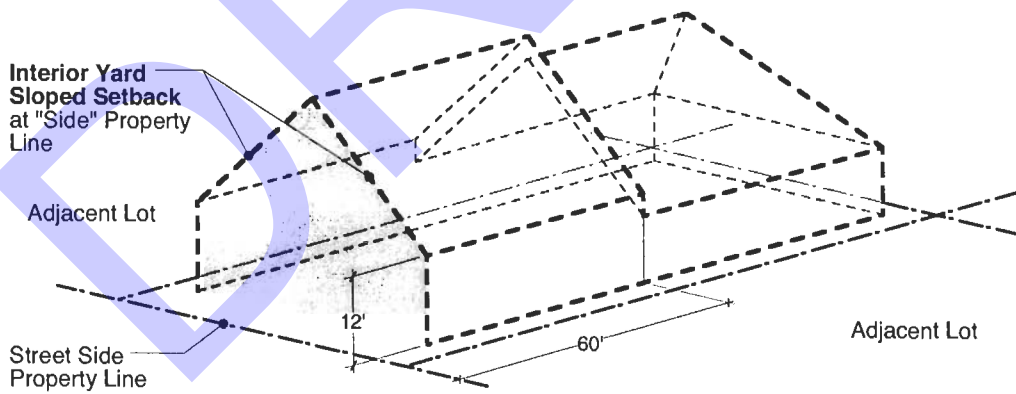

Figure 9.3065(3)(b)2.b

Interior Yard Setbacks (Front)



FRONT SECTION / ELEVATION DIAGRAM



PERSPECTIVE DIAGRAM

Figure 9.3065(3)(b)2.c

Interior Yard Setbacks (Rear)

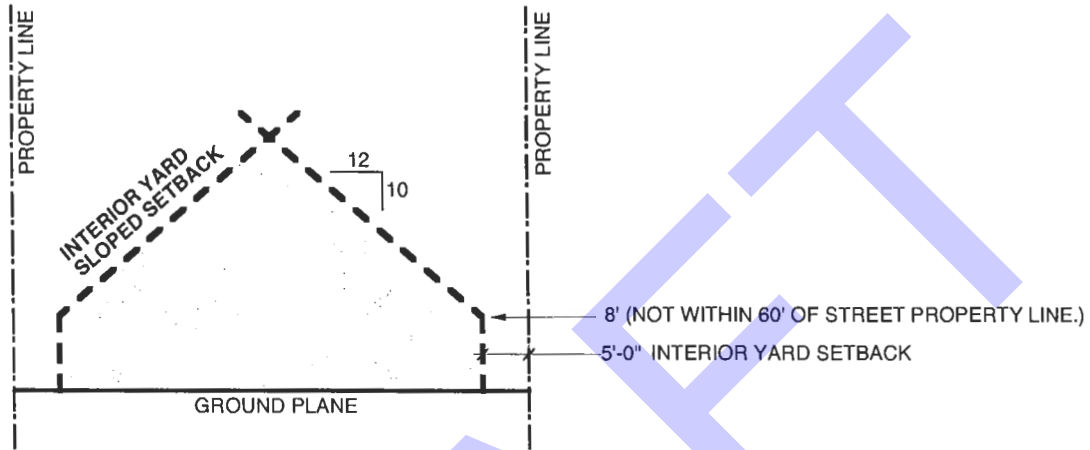

REAR SECTION / ELEVATION DIAGRAM

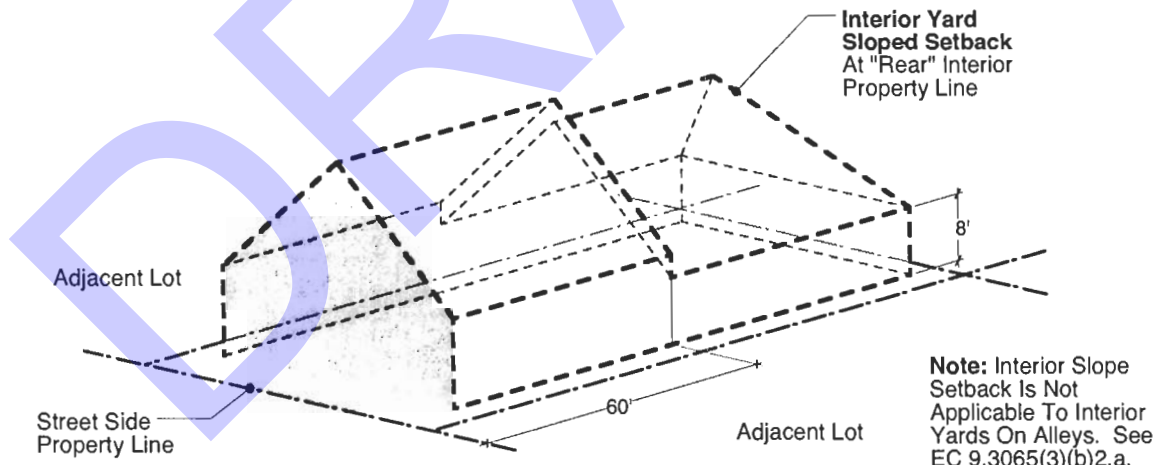

Note: Interior Slope Setback Is Not Applicable To Interior Yards On Alleys. See EC 9.3065(3)(b)2.a.

PERSPECTIVE DIAGRAM

Figure
9.3065(3)(b)2.e

Interior Yard Setbacks (Gables)

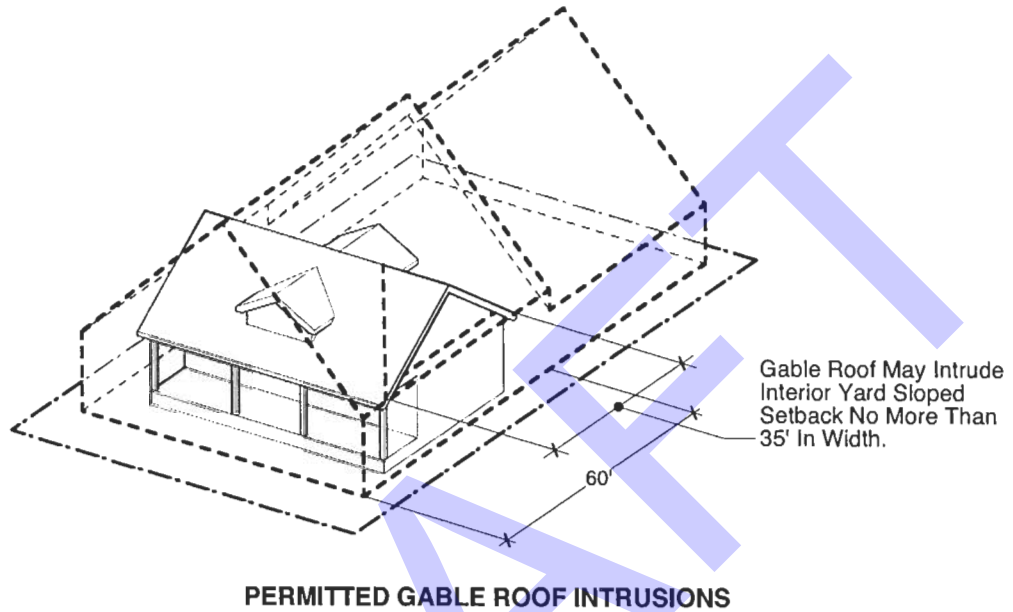

Figure
9.3065(3)(b)2.f

Interior Yard Setbacks (Dormers)

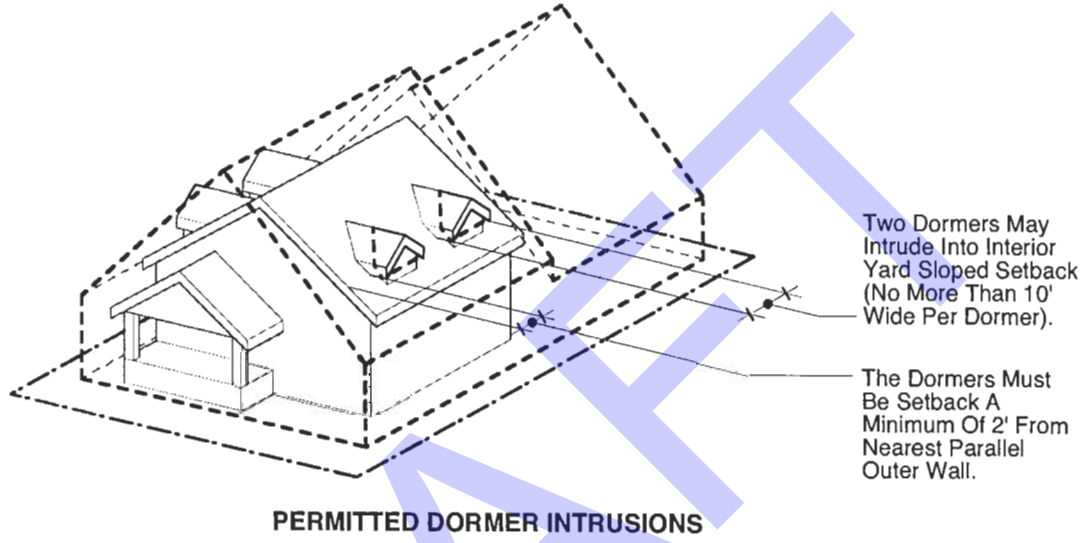
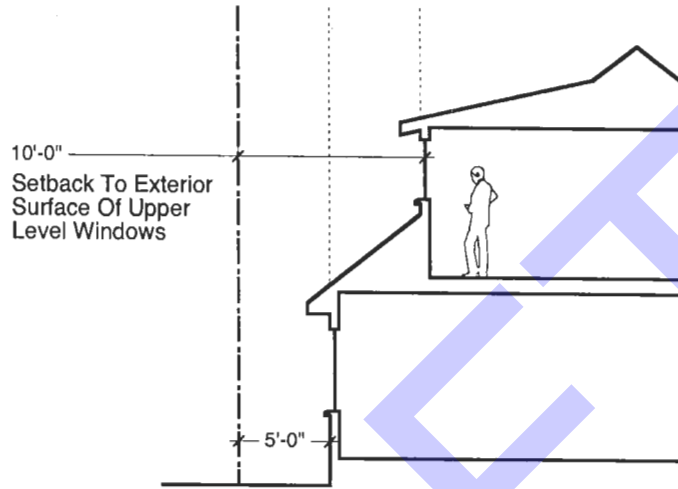
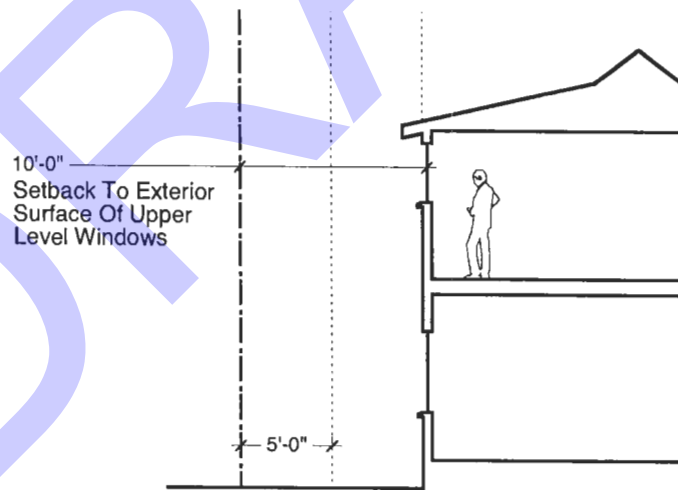

Figure
9.3065(3)(b)3

Interior Yard Setbacks (Windows)



EXAMPLE A



EXAMPLE B